

CPS CABLE DRAG CHAINS - N TYPE

CPS030 / CPS033 (BOTH SIDE OPEN)



Technical Details :	
Chain Material	Glass fibre reinforced Polyamide, UL 94-HB
Noise	40 dB (DIN EN 61672-1)
Applications	Gantry Robot, Machine Center, Textile Machine, Welding Machine, Wood Work Machine and Fabric Machine
Speed	10m / sec
Temperature Range	-30° C to +130° C Continuous
Vertical Installation Lengths	Curve above = max. 1.5 m Curve below = max. 10 m Side mounted, Unsupported = max. 0.6 m
Approvals	

CPS030

Bending Radius R	38	48	75	100
Lp	240	271	356	434
Lf	110	119	148	173
H	101	121	175	225

CPS033

Bending Radius R	35	45	75	100	120
Lp	242	274	368	446	509
Lf	117	127	157	182	202
H	101	121	181	231	271
Technical Dimensions (mm)					

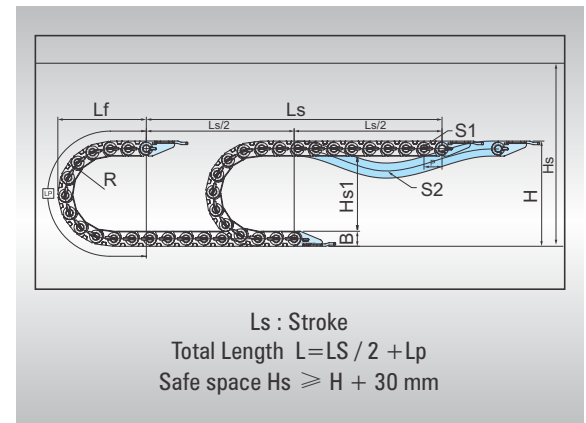

Chain Cross Section

Cat. No.	A	B	C	D	Bending Radius
CPS030.15	29	26	15	19	38,48,75,100
CPS030.25	39	26	25	19	
CPS030.35	49	26	35	19	
CPS030.50	64	26	50	19	
CPS033.27	45	31	27	23	35, 45, 75, 100, 120
CPS033.37	43	31	37	23	
CPS033.47	53	31	47	23	
CPS033.67	83	31	67	23	
CPS033.77	93	31	77	23	

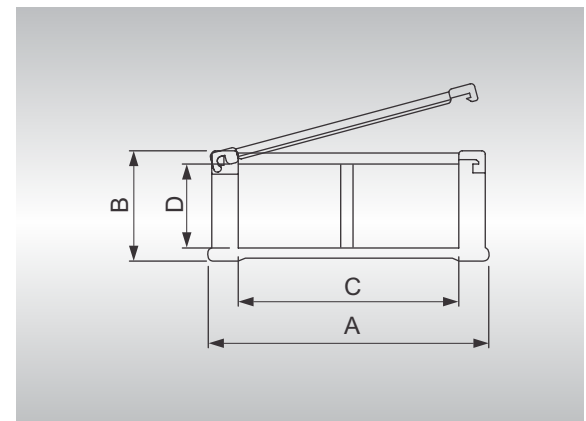

End Bracket (Polyamide)

Cat. No.	End Bracket Type	Suitable for Chain Size
S-TEB030.15/25/35/50	Tiewrap (B1/B2/B3)	CPS030
S-EEB033.27/37/47/67/77	Easy (B0)	CPS033

End Bracket Mounting Method

